



**DATA SHEET 29 – FIG TC704 CONICAL (WITCHES HAT) STRAINER**

**SIZES:** 1" to 36" NB Larger on request

**TO SUIT FLANGES TO:** ANSI B16.5/47 series A  
BS4504/DIN  
BS10  
JIS

**END CONNECTIONS:** RF / RTJ

**STANDARDS:** EN10204 2.1

**FINISH:** None as welded

**NDT:** PMI on request

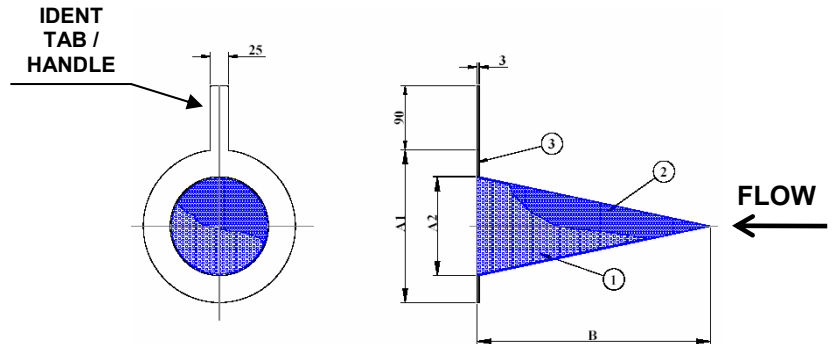

**Dimensions approx (mm)**

NB	A1 150 RF	A1 300 RF	A1 600 RF	A2	B Short Pattern	B Long Pattern	~Weight KG Short Pattern	~Weight KG Long Pattern
1"/25mm	62	69	69	22	38	50	0.2	0.2
1¼ 32mm	70	74	74	28	65	89	0.2	0.25
1½"/40mm	79	88	88	31	101	139	0.2	0.26
2"/50mm	98	104	104	44	114	152	0.2	0.28
2½" 65mm	116	122	122	64	120	189		0.32
3"/80mm	130	142	142	67	165	228	0.4	0.4
4"/100mm	168	174	187	88	215	292	0.6	0.7
5"/125mm	187	207	232	109	300	392	1.0	1.3
6"/150mm	215	244	260	139	330	431	1.1	1.5
8"/200mm	273	301	314	181	431	584	2.0	2.7
10"/250mm	333	355	393	228	533	685	2.7	3.4
12"/300mm	403	415	450	276	635	825	3.6	4.9
14"/350mm	444	479	485	320	660	889	4.5	5.4
16"/400mm	508	533	558	368	749	990	5.4	7.2
18"/450mm	542	590	606	415	838	1117	6.8	9.5
20"/500mm	600	647	676	466	939	1244	9.0	11.7
24"/600mm	711	768	784	568	1117	1473	12.2	16.3
28"/700mm	815	880	895	680	1305	1729	16.8	22.1
30"/800mm	911	906	936	967	1600	2130	25	40
36"/900mm	1040	1110	1120	840	1830	2435	30	45

**NOTES**

- Standard screen – 3 mm perf. (Mesh overlay available on request)
- Alternative length **B** available on request or to suit process conditions
- Standard flow direction is from outside of cone to in.
- Screen handle/Ident tab will be stamped to indicate size, rating & tag no where applicable
- Rings are as rolled un-machined as standard. (Machined rings available on request)
- A1** dimensions for other flange rating available on request
- Screens are not pressure retaining items and should not be exposed to a differential pressure in excess of 0.5 Bar G without our consent.
- Manufactured in the UK - Materials from UK/EU stockists

**Materials of construction**

ITEM		STAINLESS STEEL	
1/2	CONE (FABRICATED) / MESH	304	316
3	RING/TAB	304	316

**NOTES**

- Other materials such 316LSS, **Monel, Hastelloy, Inconel, Duplex & Super Duplex stainless steels** and other special alloys available on request
- High pressure units available on request