

# KAYSAFE ENGINEERING LTD

Lawson Street  
North Shields.  
Newcastle, NE29 6TG  
UNITED KINGDOM



Tel :00 44 (0) 1737 772210  
Tel: (alt):00 44 (0) 191 259181  
[www.kaysafe.co.uk](http://www.kaysafe.co.uk)

e-mail – [sales@kaysafe.co.uk](mailto:sales@kaysafe.co.uk)

## DATA SHEET 18 – FIG Y2500 Y TYPE STRAINER

<b>SIZES:</b>	½" to 1" NB
<b>PRESSURE:</b>	ANSI CLASS 2500
<b>END CONNECTIONS:</b>	NPT/BSP/SW/BW
<b>STANDARDS:</b>	ANSI B16.11/16.1.20.1/16.25
<b>CERTIFICATION:</b>	EN10204 3.1.B (C on request) NACE MR01-75 PED 2014/68/EU (CE marked where applicable) (Formerly 97/23/EC)
<b>NDT:</b>	Hydro test as standard (MPI/DPI/PMI available on request)
<b>FINISH:</b>	None, as forged (Special paint finish available on request)

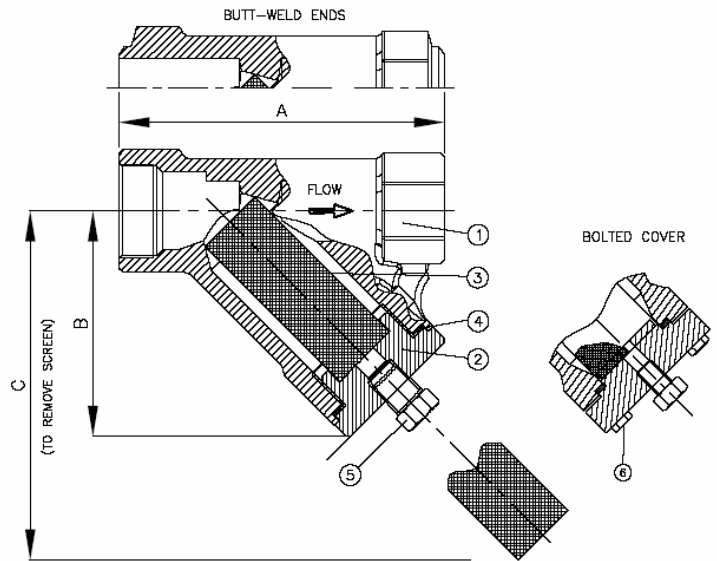

### Dimensions approx (mm) (Screwed cover)

NB	A	B	C	Wt (Kg)
½"	110	75	140	1
¾"	130	93	150	2
1"	160	120	195	6

### Dimensions approx (mm) (Bolted cover)

NB	A	B	C	Wt (Kg)
½"	165	137	165	3
¾"	165	137	165	5
1"	165	137	165	7.5
1 ¼"	190	160	280	8.5
1 ½"	190	160	280	8.5
2"	213	190	290	11.4

### NOTES

1. Drain plug – ¼" NPT on ½" to 1 ½" NB, ½" NPT on 2" NB. Flanged or SW drain available on request
2. Standard screen – 0.8 mm perf. (Mesh & Perf changes available on request)
3. Screwed covers on ½" to 1 ½" NB - bolted cover on 2" NB.
4. Special materials including 304, 321, LF2, MONEL, Hastelloy, Inconel, Incolloy, F51 & F53 and other special alloys available on request
5. Screens are not pressure retaining items and should not be exposed to a differential pressure in excess of 0.5 Bar G without our consent.
6. Certification applicable on stock items 3.1 pressure containing parts only/2.1 balance of materials
7. Modifications: Cleaning/Painting/Flanged drains/DP Points/Exotic screen materials, etc.
8. All customer specified screen changes to size of Mesh & Perf manufactured and fitted in the UK.
9. Country of origin –Italy

### Materials of construction

ITEM	CARBON STEEL		STAINLESS STEEL	
	ASTM A105N	A350 LF2	ASTM A182 F316/L SS	ASTM A182 F321 SS
1 BODY (FORGED)	ASTM A105N	A350 LF2	ASTM A182 F316/L SS	ASTM A182 F321 SS
2 COVER (FORGED)	ASTM A105N	A350 LF2	ASTM A182 F316/L SS	ASTM A182 F321 SS
3 SCREEN **	316/L st.st.		316/L st.st.	
4 COVER GASKET **	Spiral wound 316/L st.st.+Graphite / RTJ		Spiral wound 316/L st.st.+Graphite / RTJ	
5 DRAIN PLUG	ASTM A105N	ASTM A350 LF2	ASTM A182 F316/L SS	ASTM A182 F321 SS
6 BOLTING (On 2" only)	ASTM A193 B7	ASTM A320 L7	ASTM A193 B8	

### NOTES

SPARES AS MARKED \*\*

All data is subject to confirmation at the time of order. Our policy is one of continual improvement and we reserve the right to amend details without prior notice. This datasheet, its concept, design and "copyright" are the property of Kaysafe Engineering Limited and cannot be legally copied or reproduced without the written authority of said Company.